

## T 8220 EN

### Pneumatic Shut-off Butterfly Valve Type 3335/31a-SRP or Type 3335/31a-DAP

#### Application

Tight-closing butterfly valve for process engineering and industrial applications

**Valve size** DN 50 to 300 · NPS 2 to 12

**Pressure rating PN 10 and 16**

**Max. operating pressure 10 or 16 bar**

**Temperatures** -10 to +150 °C · 14 to 302 °F

Type 3335/31a Shut-off Butterfly Valve with

- Type 3335 Butterfly Valve and single-acting Type 31a-SRP Pneumatic Rotary Actuator

Valve body made of

- Cast iron
- Spheroidal graphite iron

Seat ring made of

- EPDM
- PTFE

Butterfly disk made of

- Spheroidal graphite iron
- Cast stainless steel
- PTFE-coated

Attachment of control valve accessories, such as pneumatic or electropneumatic positioners, electrical or pneumatic limit switches or solenoid valves according to VDI/VDE 3845.

#### Throttling service

The butterfly valve can also be used for throttling service in the rotation range from 25° to 60°.

#### Versions

Standard version · Valve size DN 50 to 300

- **Type 3335/31a** (Fig. 1) · Type 3335 with single-acting Type 31a-SRP Pneumatic Rotary Actuator

#### Further versions

- Double-acting Type DAP Rotary Actuator
- Larger valve sizes on request
- Emergency manual override for Pfeiffer Type 31a-SRP and Type 31a-DAP Rotary Actuators
- Single-acting Type 3278 Pneumatic Rotary Actuator
- Special materials



**Fig. 1:** Type 3335/31a Pneumatic Butterfly Valve



**Fig. 2:** Type 3335/3278 Pneumatic Butterfly Valve

### Principle of operation

The medium flows through the butterfly valve. The flow coefficient depends on the opening angle of the butterfly disk (4) and, as a result, the cross-sectional area between the disk and the body. The disk is connected to the actuator by the shaft and coupling elements.

The disk and the seat ring (3) come into contact with the process medium. The seat ring also functions as a flange seal.

### Fail-safe position

Depending on the version of the rotary actuator, the butterfly valve has two different fail-safe positions which become effective when the pressure is reduced or when supply air fails:

#### Fail-close

The butterfly valve is closed when the supply air fails.

#### Fail-open

The butterfly valve opens when the supply air fails.

### Legend

- 1 Bearing bushing with O-ring
- 3 Seat ring
- 4 Butterfly disk with shaft
- 5 Retainer
- 6 Disk spring
- 8 Elastomer
- 10 Mounting plate

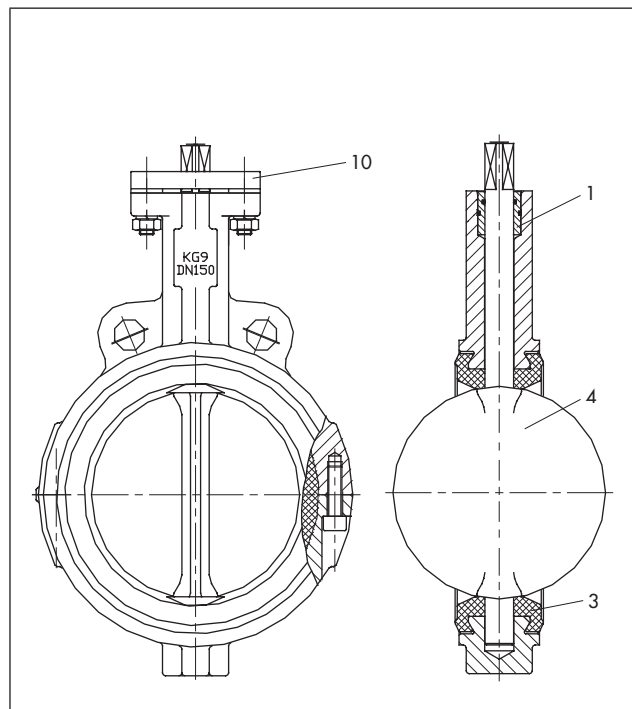

Fig. 3: Type 3335 Butterfly Valve  
version with EPDM seat ring

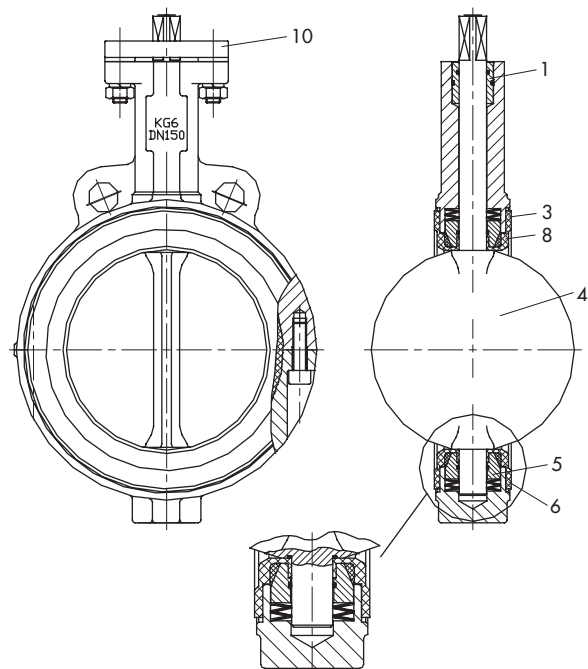

Fig. 4: Type 3335 Butterfly Valve  
version with PTFE seat ring

**Table 1: Technical data**

Valve size <sup>1)</sup>	DN 50 to 300 · NPS 2 to 12		DN 50 to 150 · NPS 2 to 6	
Pressure rating	PN 10		PN 10 · PN 16 on request	
Body style	Wafer-type · Lug-type on request			
Overall length	EN 558-1 Series 20 (DIN 3202 K1)			
Mounted between flanges	PN 10, PN 16 or Class 150			
Temperature range				
Seat ring	EPDM	-10 to +120 °C (14 to 248 °F)		
	PTFE	-10 to +150 °C (14 to 302 °F)		
Permissible operating pressures				
Seat ring <sup>2)</sup>	EPDM	10 bar · 9.5 bar at 120 °C	16 bar on request only with body of EN-GJS-400-18-LT	
	PTFE	10 bar up to 50 °C · 7 bar at 150 °C		
Leakage class according to IEC 12266-1	Test P12, leakage rate A			

<sup>1)</sup> Larger valve sizes on request

<sup>2)</sup> Special version for vacuum service (100 mbar abs.)

**Table 2: Materials**

Body	Cast iron EN-GJL-250	Spheroidal graphite iron EN-GJS-400-18-LT	Spheroidal graphite iron EN-GJS-400-18-LT	
Seat ring	EPDM · Others (e.g. silicone on request)		PTFE	
Elastomer	-		Silicone	
Butterfly disk	EN-JS1030 (CrNiMo steel up to DN 150/NPS 6)		CrNiMo steel	PTFE-coated
	CrNiMo steel			
Shaft	1.4021 (CrNiMo steel up to DN 150/NPS 6)		CrNiMo steel	1.4462
	CrNiMo steel			
Compressor	-		1.4305	
Bearing bushing with O-ring	POM/NBR		POM/NBR	
Disk spring	-		Spring steel	

**Table 3:  $K_{VS}$  coefficients**

Valve size		Opening angle								
DN	NPS	10°	20°	30°	40°	50°	60°	70°	80°	90°
50	2	1.8	7	16	26	44	70	115	175	210
65	2 ½	2.8	10	23	39	60	95	155	280	340
80	3	3.5	14	33	57	95	146	240	380	510
100	4	5.5	25	54	95	155	240	395	620	820
125	5	8.6	38	86	155	240	385	635	950	1200
150	6	14.5	52	120	215	342	547	940	1380	1800
200	8	20.5	95	215	376	590	940	1540	2400	3200
250	10	33	154	342	607	940	1540	2310	4000	5300
300	12	49	222	504	855	1455	2310	3760	6000	8000

**Table 4:** Differential pressure tables for Type 3335 Shut-off Butterfly valve · All pressures in bar

**Table 4.1:** Permissible differential pressures (fail-close)

Valve size		Shaft Ø	Actuator size of Type SRP	Number of springs n =	Required signal pressure <sup>1)</sup>	Differential pressure <sup>2)</sup>	Max. permissible supply pressure with shaft of		
DN	NPS						1.4021	CrNiMo steel	1.4462
50	2	14	150	3	2.5	16	-	4.1	6.0
			100	4/5	4			6	6.0
65	2 ½	14	220	2/3	2.5	16		2.8	4.6
			150	4	3.5	16		4.5	6.0
			100	5/6	5	16		6	6.0
80	3	14	220	3	2.5	16		2.9	4.8
			150	4/5	4	10		4.7	6.0
			100	6	5.5	10		6	6.0
100	4	16	300	3	2.5	5		3.3	5.4
			220	4/5	4	16		4.4	6.0
			150	6	5.5	5		6	6.0
125	5	19	450	3	2.5	16		3.4	5.7
			300	4/5	4	5	5.3	6.0	
			220	6	5.5	16	6	6.0	
150	6	19	600	3	2.5	5	2.9	4.7	
			450	4/5	4	10	-	6.0	
			300	6	5.5	5	6	6.0	
200	8	22	1200	3	2.5	10	3.7	3.4	5.7
			900	4/5	4	16	5.1	4.7	6.0
			600	6	5.5	10	6	6	6.0
250	10	29	2000	3	2.5	16	3.3	3.1	5.1
			1200	4/5	4	10	5.6	5.1	6.0
			900	6	5.5	10	6	6	6.0
300	12	29	3000	2/3	2.3	10	2.6	-	3.7
			1200	5/6	5	5	6	5.5	6.0

<sup>1)</sup> Required supply pressure to open the valve

<sup>2)</sup> When the valve is closed, the differential pressure is restricted by the valve version (see Table 1).

**Table 4.2:** Permissible differential pressures (fail-open)

Valve size		Shaft Ø	Actuator size of Type SRP	Number of springs n =	Required signal pressure <sup>1)</sup>	Differential pressure <sup>2)</sup>	Max. permissible supply pressure with shaft of		
DN	NPS						1.4021	CrNiMo steel	1.4462
50	2	14	150	2	2.5	16	-	3.8	6.0
			100	3/4	4			5.5	6.0
65	2 ½	14	220	2	2.5	16		2.6	4.4
			150	3/4	4	16		4.3	6.0
			100	5	5.5	16		6	6.0
80	3	14	220	2	2.5	16		2.6	4.4
			150	3/4	4	16		4.3	6.0
			100	5	5.5	5		6	6.0
100	4	16	300	2	2.5	10		2.9	5.1
			220	3	3.5	16		3.8	6.0
			150	5	5.5	10		6	6.0
125	5	19	450	2	2.5	16		3	5.3
			300	3/4	4	16	4.9	6.0	
			220	5	5.5	16	6	6.0	
150	6	19	600	2	2.5	10	2.6	4.3	
			450	3/4	3.5	5	3.6	5.8	
			300	5	5.5	10	5.6	6.0	
200	8	22	1200	2	2.5	10	3.4	3	5.3
			900	3/4	4	16	4.9	4.5	6.0
			600	5	5.5	16	6	6	6.0
250	10	29	2000	2	2.5	16	3	2.7	4.8
			1200	3/4	4	10	5.2	4.8	6.0
			900	5	5.5	10	6	6	6.0
300	12	29	2000	2/3	3	10	3.2	-	4.9
			1200	5	5.5	10	5.7	-	6.0

<sup>1)</sup> Required supply pressure to close the valve

<sup>2)</sup> When the valve is closed, the differential pressure is restricted by the valve version (see Table 1).

**A differential pressure of at least 10 bar is required when the seat ring is made of PTFE.**

**Table 5:** Shaft torque as well as opening and closing torques in Nm

Valve size		Perm. shaft torque (up to 20 °C/68 °F) with material			Opening and closing torques at $\Delta p$		
DN	NPS	1.4021	CrNiMo steel	1.4462	5 bar <sup>1)</sup>	10 bar	16 bar
50	2	-	79	158	28	29	29
65	2½		79	158	33	34	36
80	3		79	158	39	44	47
100	4		118	236	59	64	69
125	5		198	396	83	98	98
150	6		198	396	123	137	157
200	8	552	480	960	206	235	275
250	10	814	703	1406	314	363	412
300	12	814	703	1406	441	530	589

<sup>1)</sup> The higher torques in the column for 10 bar apply to a differential pressure of 5 bar when the seat ring is made of PTFE.

**Table 6:** Dimensions and weights for Type 3335/31a Pneumatic Butterfly Valve

Valve	DN	50	65	80	100	125	150	200	250	300
	NPS	2	2½	3	4	5	6	8	10	12
Length L	mm	43	46	46	52	56	56	60	68	78
Shaft $\varnothing$	mm	14	14	14	16	20	20	22	28	28
B	mm	60	67	75	94	113	126	158	191	222
A	mm	145	160	175	195	210	225	258	288	318
Flange	DIN 3337	F07	F07/F10	F07/F10	F07/F10	F10/F12	F10/F12	F12/F14	F14/F16	F14/F16
AF	mm	17	17/22	17/22	17/22	22/27	22/27	27/36	36/46	36/46
C (mounting plate)		12	12	12	12	12	12	12	12	12
Weight	kg (approx.)	2.8	3.3	3.8	5.5	7.5	9.3	15	22	33

**Table 7:** Dimensions and weights for Type SRP Rotary Actuator

Size		100	150	220	300	450	600	900	1200	2000	3000
H3	mm	248	269	315	345	409	438	487	543	621	684
E	mm	135	147	175	187	207	226	271	295	349	380
Connecting flange DIN 3337		F07	F07	F10	F10	F12	F12	F14	F14	F16	F16
AF	mm	17	17	22	22	27	27	36	36	46	46
Weight	kg	4.5	6.5	10	13	18.5	24	32	46	65	103

**Order specifications:**

Valve size	DN ...
Pressure rating	PN ...
Material	For body, butterfly disk and seat ring according to Table 2
Actuator	Pfeiffer Type 31a or Type 3278
Fail-safe position	Fail-close or fail-open
Medium temperature	°C or K
Max. differential pressure	$\Delta p_0$ in bar (closed position)
sure	
Supply pressure	... bar
Vacuum service	Yes/No ( ... mbar <sub>abs</sub> )
Valve accessories	

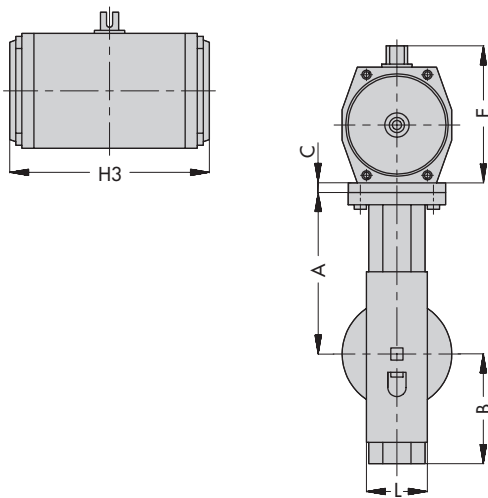
**Dimensional drawing**

Type 3335/31a Butterfly Valve

Information Sheet for actuators **▶ T 8300**  
Associated Mounting and Operating Instructions **▶ EB 8220**