

T 3004 EN

Series 42 Self-operated Regulators · Type 42-24 and Type 42-28 Differential Pressure Regulators With Type 2424/Type 2428 Actuator (closing) and balanced Type 2422 Valve ANSI version



Application

Differential pressure regulators for district heating systems, extended heating systems and industrial applications

Differential pressure set points (Δp) **from 0.75 to 145 psi/0.05 to 10 bar** · Valves **NPS ½ to 10¹⁾/DN 15 to 250¹⁾** · Pressure rating **Class 125 to 300/PN 16 to 40** · Suitable for liquids and vapors²⁾ from **40 to 660 °F/5 to 350 °C**, for air and non-flammable gases up to **175 °F/80 °C**

The valve **closes** when the differential pressure **rises**.

The regulators control the differential pressure according to the adjusted set point.

Special features

- **Type 42-24:** Set point adjustable in wide range
- **Type 42-28:** Fixed set point
- Low-noise, medium-controlled proportional regulator requiring little maintenance
- Suitable for circuit water, water/glycol mixtures, steam and air as well as other liquids, gases and vapors, provided these do not affect the characteristics of the operating diaphragm
- Valve body available in cast iron, cast steel and cast stainless steel
- Single-seated valve with a plug balanced by a stainless steel bellows or a diaphragm (NPS 2½ to 10/DN 65 to 250)
- Particularly suitable for district heating supply networks

Versions

Differential pressure regulators for installation in the flow pipe and return flow pipe (see Fig. 5) · Flanged connections

- **Type 42-24** (Fig. 1) · Type 2422 Valve · Balanced by a bellows NPS ½ to 10/DN 15 to 250 · Balanced by a diaphragm NPS 2½ to 10/DN 65 to 250 · Type 2424 Actuator with adjustable set point
- **Type 42-28** (Fig. 2) · Type 2422 Valve · Balanced by a bellows NPS ½ to 4/DN 15 to 100 · Balanced by a diaphragm NPS 2½ to 4/DN 65 to 100 · Type 2428 Actuator with fixed set point, adjusted to $\Delta p = 3, 4, 6$ or $7 \text{ psi}/0.2, 0.3, 0.4$ or 0.5 bar

¹⁾ Valves larger than NPS 10/DN 250 on request

²⁾ Version balanced by a bellows only

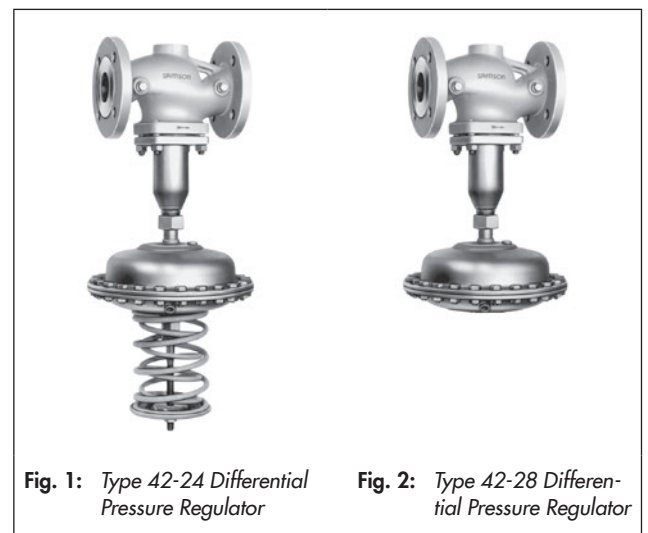

Fig. 1: Type 42-24 Differential Pressure Regulator

Fig. 2: Type 42-28 Differential Pressure Regulator

Accessories

Required accessories, such as compression-type fittings, needle valves, compensation chambers and control lines, are listed in Data Sheet ▶ T 3095.

Special versions

- DIN and JIS versions on request
- Versions free of non-ferrous metal on request
- Actuator with two diaphragms
- Version for temperatures above 430 °F/220 °C
- Version for deionized water
- Version for mineral oils which do not affect the characteristics of the FKM diaphragm; other oils on request
- Type 2422 Valve · DN 15 to 50 without pressure balancing
- Special set point 8 to 16 bar for valves \leq DN 100 on request
- Version for small flow rates · Valve with micro trim with C_v 0.0012 to 0.05/ K_{VS} 0.001 to 0.04 or C_v 0.12, 0.5 and 1.2/ K_{VS} 0.1, 0.4 and 1.0 without pressure balancing

Principle of operation (Fig. 3)

The medium flows through the valve in the direction indicated by the arrow. The position of the valve plug (3) determines the differential pressure over the cross-sectional area released between the plug (3) and seat (2).

The Type 2422 Valve is balanced. The forces acting on the valve plug created by the upstream and downstream pressures are balanced by a balancing bellows (5) or balancing diaphragm (5.1). Regulators balanced by a bellows or a diaphragm only differ in the pressure balancing principle applied. Valves balanced by a diaphragm have a balancing diaphragm (5.1) instead of the balancing bellows. The downstream pressure p_2 acts on the bottom of the diaphragm and the upstream pressure p_1 on the top of the diaphragm. As a result, the forces created by the upstream and downstream pressures acting on the plug are balanced out.

The differential pressure to be controlled is transferred to the operating diaphragm (13) where it is transformed into a posi-

tioning force. This force is used to move the plug (3) according to the force of the set point springs (16). The valve begins to close as soon as the differential pressure exceeds the set point.

The set point of Type 42-24 can be adjusted at the set point adjuster (SW 27, 17). In Type 42-28, the set point springs in the actuator determines the set point.

A seal in the actuator separates the pressure in the valve from the pressure in the actuator.

Control lines (20) mounted on site transfer the high pressure (+) and low pressure (-) in both regulator versions.

Type 2424 and Type 2428 Actuators are equipped with an overload protection (21). It prevents a rise in differential pressure during extreme operating conditions (e.g. vacuum at the heat exchanger) by opening an internal excess pressure limiter. As a result, plants and the regulator itself are protected against excessively high differential pressures.

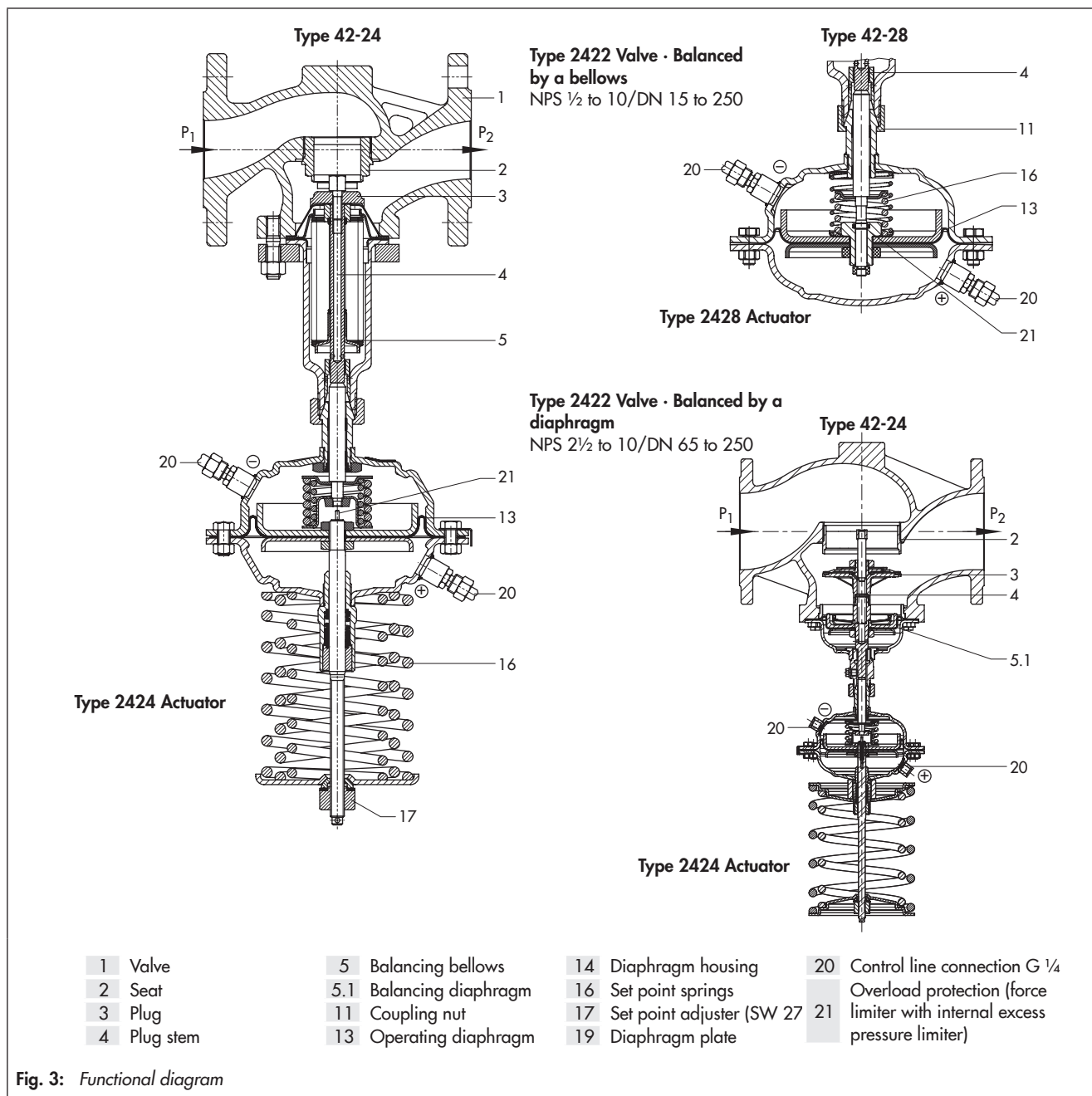

Fig. 3: Functional diagram

Type 42-24 Differential Pressure Regulator with two diaphragms

SAMSON offers a special version of Type 42-24 with an actuator with two diaphragms (see Fig. 4). The actuator with two diaphragms provides increased functional reliability.

An actuator with two diaphragms is always required when an FKM diaphragm is to be used. It is especially suitable for applications with thin oils (e.g. heat transfer oil).

The two diaphragms separate both diaphragm chambers connected to the high-pressure and low-pressure connections. They generate a positioning force from the differential pressure. A mechanical diaphragm rupture indicator (22) is located between the two diaphragms, which responds at approx. 1.5 bar. In the event of a diaphragm rupture, the pressure in the space between the two operating diaphragm starts to increase. This causes the pin in the diaphragm rupture indicator to be pushed outwards and a red ring appears, indicating the diaphragm rupture. The intact operating diaphragm takes on the control task of the ruptured diaphragm.

A pressure switch can be optionally mounted to the actuator to trigger an alarm.

We recommend replacing both diaphragms after a diaphragm rupture is indicated.

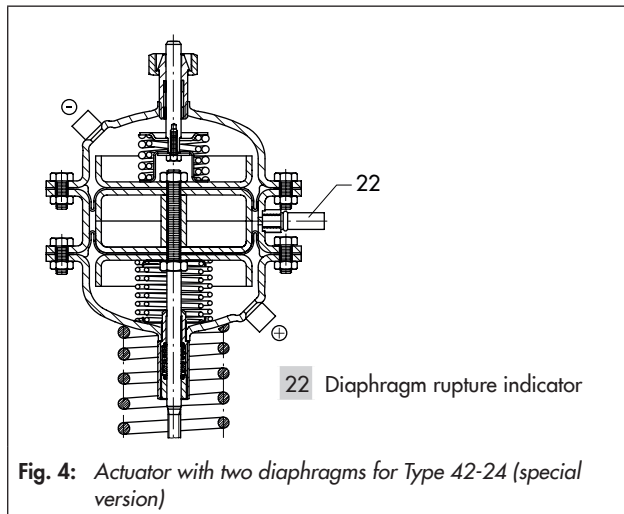

Installing the valve and mounting the actuator

Valve, actuator and control lines (accessories) are delivered unattached.

A coupling nut is used to attach the actuator to the valve. Preferably mount the actuator after the valve is installed.

The following points must be observed:

- Install the valve in horizontal pipelines.
- The direction of flow must match the direction indicated by the arrow on the body.
- Install a strainer (e.g. SAMSON Type 2 NI) upstream of the valve.

Permissible mounting positions

- Actuator suspended: standard installation, balanced by a bellows or diaphragm, all versions, above 175 °F/80 °F. Steam control only for version with balanced by a bellows.
- Actuator sideways: versions balanced by a bellows with fixed plug guide or all versions balanced by a diaphragm
- Actuator upright (actuator on top of the valve): all versions balanced by a diaphragm, versions balanced by a bellows NPS ½ to 3/DN 15 to 80 and at the same time max. 175 °F/80 °C.

Refer to ► EB 3003 for more details.

Ordering text

Type 42-24 and Type 42-28 Differential Pressure Regulator

Installation in flow pipe/return flow pipe

NPS ... , valve balanced by a bellows/diaphragm

Class ... , body material ...

Set point or set point range ... psi

Optionally, accessories ...

Optionally, special version

Application

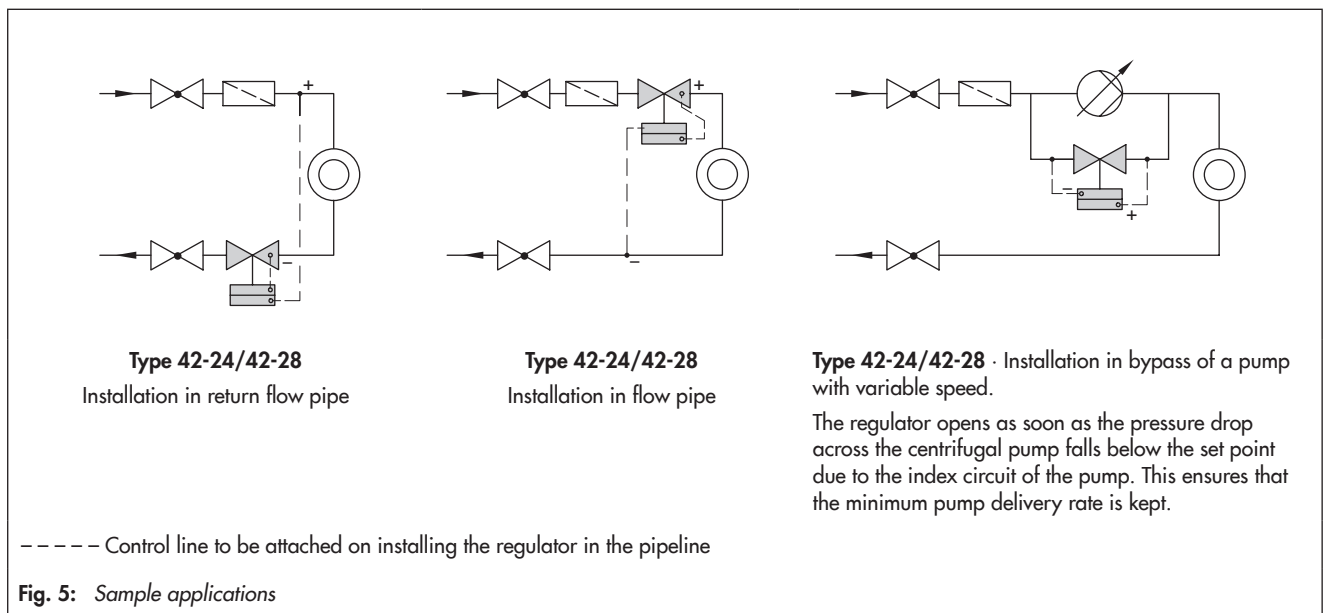



Table 1: Technical data

Type	42-24				42-28		
Valve size	NPS ½ to 10 · DN 15 to 250				NPS ½ to 4 · DN 15 to 100		
Pressure rating	Class 125, 150 and 300/PN 16, 25 and 40						
Max. permissible temperature	Valve	See pressure-temperature diagram in ► T 3000					
	Actuator ¹⁾	With compensation chamber: steam and liquids up to 430 °F ²⁾ /220 °C ²⁾ Without compensation chamber: liquids up to 300 °F/150 °C, air and gases up to 175 °F/80 °C					
Set point ranges	psi	0.75 to 3.5 · 1.5 to 8.5 · 3 to 14.5 · 7 to 20 · 14.5 to 35 · 30 to 75 · 65 to 145 ³⁾				3 · 4 · 6 · 7	
	bar	0.05 to 0.25 · 0.1 to 0.6 · 0.2 to 1 · 0.5 to 1.5 · 1 to 2.5 · 2 to 5 · 4.5 to 10 ³⁾				0.2 · 0.3 · 0.4 · 0.5	
Actuator area A	in ²	12	25	50	100	25	50
	cm ²	80	160	320	640	160	320
Pressure above adjusted set point at which internal excess pressure limiter responds	psi	35	17.5	9	4	9	4
	bar	2.4	1.2	0.6	0.3	0.6	0.3
Max. perm. operating pressure for actuator with two diaphragms	psi	580		360		-	
	bar	40		25		-	
Conformity							
Leakage class acc. to IEC 60534-4	≤0.05 % of C _v /K _{vS} coefficient						

¹⁾ Max. 350 °C/660 °F with extension piece

²⁾ Steam version only with valves balanced by a bellows

³⁾ NPS 6 to 10/DN 150 to 250: 65 to 145 psi/4.5 to 10 bar on request

Table 2: Materials · Material numbers according to DIN EN
Table 2.1: Materials for Type 2422 Valve

Type 2422 Valve · Balanced by a bellows			
Valve size	NPS ½ to 10/DN 15 to 250		
Pressure rating	Class 125	Class 150 and 300	
Valve body	Cast iron A126B	Cast steel A216 WCC	Cast stainless steel A351 CF8M
Valve seat	Stainless steel 1.4104 or 1.4006		1.4404
Plug	Up to NPS 4/DN 100 ¹⁾	Stainless steel 1.4404	
	NPS 6 to 10/DN 150 to 250	1.4404, with PTFE soft seal	
Plug stem	1.4301		
Metal bellows	1.4571 · NPS 6/DN 150 and larger: 1.4404		
Bottom section	P265GH		1.4571
Body gasket	Graphite on metal core		
Type 2422 Valve · Balanced by a diaphragm			
Valve size	NPS 2½ to 4 · DN 65 to 100		
Pressure rating	Class 125	Class 150	
Valve body	Cast iron A126B	Cast steel A216 WCC	
Valve seat	1.4408		
Plug	CW617N		
Diaphragm cases	1.0619		
Pressure balancing	Diaphragm plate 1.4301 · EPDM balancing diaphragm, max. 300 °F/150 °C or NBR diaphragm, max. 175 °F/80 °C		
Valve size	NPS 6 to 10 · DN 150 to 250		
Pressure rating	Class 125	Class 150 and 300	Class 150 and 300
Valve body	Cast iron A126B	Cast steel A216 WCC	Cast stainless steel A351 CF8M
Valve seat	CC499K ²⁾		
Plug	CC499K ²⁾ · With EPDM soft seal, max. 300 °F/150 °C or with PTFE soft seal, max. 300 °F/150 °C		
Pressure balancing	Diaphragm plate EN-JS1030 · EPDM balancing diaphragm, max. 300 °F/150 °C or NBR diaphragm, max. 175 °F/80 °C		

¹⁾ Optionally with soft seal with standard C_v/K_{vS} coefficients

²⁾ Special version 1.4409

Table 2.2: Materials for Type 2424/Type 2428 Actuator

Type 2424/Type 2428 Actuator		
Valve body	Cast iron A126B · Cast steel A216 WCC	Cast stainless steel A351 CF8M
Diaphragm cases	DD 11	1.4301
Diaphragm	EPDM ¹⁾ with fabric reinforcement	
Guide bushing	DU bushing	PTFE
Seals	EPDM/PTFE ¹⁾	

¹⁾ Special version, e.g. for mineral oils: FKM using an actuator with two diaphragms

Table 3: C_V/K_{VS} coefficients, x_{FZ} values and max. permissible differential pressures Δp

Terms for control valve sizing according to IEC 60534, Parts 2-1 and 2-2: $F_L = 0.95$, $X_T = 0.75$

Type 2422 Valve · Unbalanced							
Valve size	NPS	½	¾	1	1½	2	
	DN	15	20	25	40	50	
Valve travel	0.4"/10 mm						
K_{VS}/C_V coefficient	C_V	5.0	5.0 · 7.5	5.0 · 7.5 · 9.4	23	37	
	K_{VS}	4.0	4.0 · 6.3	4.0 · 6.3 · 8.0	20	32	
Max. perm. differential pressure Δp	200 psi/14 bar			85 psi/6 bar			
x_{FZ} value	0.65	0.6	0.55	0.45	0.4		
Reduced C_V/K_{VS} coefficient	C_V	0.12 · 0.5 · 1.2 · 3.0 or 0.0012 to 0.05 (micro trim)				-	
	K_{VS}	0.1 · 0.4 · 1.0 · 2.5 or 0.001 to 0.04 (micro trim)					
Max. perm. differential pressure Δp	360 psi/25 bar						
x_{FZ} value	0.65						

Type 2422 Valve · Balanced by a bellows												
Valve size	NPS	½	¾	1	1½	2	2½	3	4	6	8	10
	DN	15	20	25	40	50	65	80	100	150	200	250
Valve travel	0.4"/10 mm				0.6"/16 mm				0.9"/22 mm			
K_{VS}/C_V coefficient	C_V	5.0	7.5	9.4	23	37	60	94	145	330	490	590
	K_{VS}	4.0	6.3	8.0	20	32	50	80	125	280	420	500
Max. perm. differential pressure Δp	360 psi/25 bar						290 psi/20 bar	230 psi/16 bar	175 psi/12 bar	145 psi/10 bar		
Reduced C_V/K_{VS} coefficient	C_V	-		5.0	9.4	20	37	94	145	330		
	K_{VS}	-		4.0	8.0	16	32	80	125	280		
Max. perm. differential pressure Δp	360 psi/25 bar								290 psi/20 bar	230 psi/16 bar	175 psi/12 bar	
x_{FZ} value	0.65	0.6	0.55	0.45	0.4	0.35	0.3					

Type 2422 Valve · Balanced by a diaphragm							
Valve size	NPS	2½	3	4	6	8	10
	DN	65	80	100	150	200	250
Valve travel	0.6"/15 mm				1.4"/35 mm		
K_{VS}/C_V coefficient	C_V	60	95	150	445	760	930
	K_{VS}	50	80	125	380	650	800
Max. perm. differential pressure Δp	145 psi/10 bar				175 psi/12 bar	145 psi/10 bar	
x_{FZ} value	0.4	0.35			0.3		

Dimensional drawings for Type 42-24 and Type 42-28 balanced by a bellows · Dimensions and weights (see Table 4)

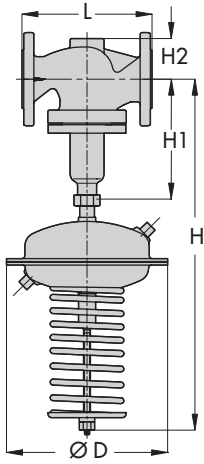

Type 42-24 · Type 2422 Valve balanced by a bellows with Type 2424 Actuator

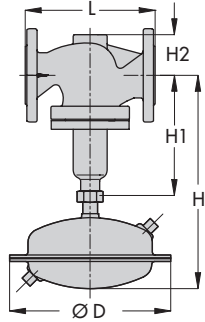

Type 42-28 · Type 2422 Valve balanced by a bellows with Type 2428 Actuator

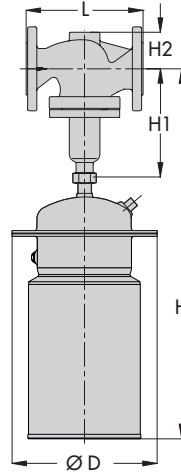

Type 42-24 · Type 2422 Valve balanced by a bellows with Type 2424 Actuator and metal cover

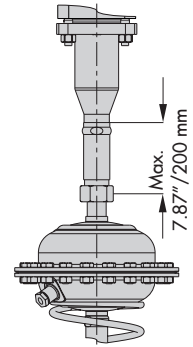

Extension piece

Type 42-24 with two diaphragms: Add approx. 2.2"/55 mm to the overall height H.

Table 4: Dimensions and weights for Type 42-24 and Type 42-28 · Balanced by a bellows

Valve size	NPS	1/2	3/4	1	1 1/2	2	2 1/2	3	4	6	8	10	
	DN	15	20	25	40	50	65	80	100	150	200	250	
Length L	Class 125 and 150	in	7.25			8.75	10	10.9	11.75	13.9	17.75	21.4	26.5
		mm	184			222	254	276	298	352	451	543	673
	Class 300	in	7.5	7.6	7.75	9.25	10.5	11.5	12.5	14.5	18.6	22.4	27.9
		mm	191	194	197	235	267	292	318	368	473	568	708
Height H1	in	8.9					11.8		14	23.2	28.7		
	mm	225					300		355	590	730		
Height H2	Cast steel	in	1.73			2.83		3.86	4.65	6.9	9.3	10.2	
		mm	44			72		98	118	175	235	260	
	Forged steel	in	2.1	-	2.76	3.62	3.86	-	5.05	-	-		
		mm	53	-	70	92	98	-	128	-	-		
Type 42-28 Differential Pressure Regulator													
Set points		Type 2428 Actuator											
3, 4, 6, 7 psi/ 0.2 · 0.3 · 0.4 · 0.5 bar	Height H ^{5) 6)}	15.4"/390 mm					18.3"/465 mm		20.5"/520 mm				
	Actuator	ØD = 8.9"/225 mm · A = 25 in ² /160 cm ² ²⁾					ØD = 11.2"/285 mm · A = 50 in ² /320 cm ²						
	Weight ³⁾	lb	25	27	29	44	50	84	95	126	-		
		kg	11.5	12	13	20	22.5	38	43	57	-		
Type 42-24 Differential Pressure Regulator													

¹⁾ Optionally with actuator 100 in²/640 cm²

²⁾ Optionally with actuator 50 in²/320 cm²

³⁾ The weight applies to the version made of cast iron A126B. Add +10 % for all other materials.

⁴⁾ NPS 6 to 10/DN 150 to 250: 65 to 145 psi/4.5 to 10 bar on request

⁵⁾ Actuators with metal cover H +5.32"/+135 mm

⁶⁾ The height H increases to 7.87"/200 mm at the maximum, depending on the extension piece used.

⁷⁾ Special version A = 25 in²/160 cm² without internal excess pressure limiter; with internal excess pressure limiter: H -2 in/50 mm

Table 4: Dimensions and weights for Type 42-24 and Type 42-28 · Balanced by a bellows

Valve size	NPS	½	¾	1	1½	2	2½	3	4	6	8	10	
	DN	15	20	25	40	50	65	80	100	150	200	250	
Set points		Type 2424 Actuator											
0.75 to 3.5 psi/ 0.05 to 0.25 bar	Height H ^{5) 6)}	24"/610 mm					30"/685 mm		29.1"/ 740 mm	44"/ 1120 mm	49.6"/1260 mm		
	Actuator	ØD = 11.2"/285 mm · A = 50 in ² /320 cm ² ¹⁾					ØD = 15.4"/390 mm · A = 100 in ² /640 cm ²						
	Weight ³⁾	lb	46	47	50	65	71	111	113	143	408	937	1069
		kg	21	21.5	22.5	29.5	32	46	51	65	185	425	485
1.5 to 8.5 psi/ 0.1 to 0.6 bar	Height H ^{5) 6)}	625					685			740	990	1120	
	Actuator	ØD = 8.9"/225 mm · A = 25 in ² /160 cm ² ²⁾					ØD = 11.2"/285 mm · A = 50 in ² /320 cm ²			ØD = 15.4"/390 mm · A = 100 in ² /640 cm ² ²⁾			
	Weight ³⁾	lb	35.3	36.3	38.5	54	60	111	113	143	408	937	1069
		kg	16	16.5	17.5	24.5	27	46	51	65	185	425	485
3 to 14.5 psi/ 0.2 to 1 bar	Height H ^{5) 6)}	24"/610 mm					30"/685 mm		29.1"/ 740 mm	44.1"/ 1120 mm	49.6"/1260 mm		
	Actuator	ØD = 8.9"/225 mm · A = 25 in ² /160 cm ² ²⁾								ØD = 15.4"/390 mm · A = 100 in ² /640 cm ²			
	Weight ³⁾	lb	35	36	39	54	60	93	104	135	408	937	1069
		kg	16	16.5	17.5	24.5	27	42	47	61	185	425	485
7 to 20 psi/ 0.5 to 1.5 bar	Height H ^{5) 6)}	24"/610 mm					30"/685 mm		29.1"/ 740 mm	40.9"/ 1040 mm	46.5"/1180 mm		
	Actuator	ØD = 8.9"/225 mm · A = 25 in ² /160 cm ² ²⁾								ØD = 11.2"/285 mm · A = 50 in ² /320 cm ²			
	Weight ³⁾	lb	35	36	39	54	60	93	104	135	386	915	1047
		kg	16	16.5	17.5	24.5	27	42	47	61	175	415	475
14.5 to 35 psi/ 1.0 to 2.5 bar	Height H ^{5) 6)}	24"/610 mm					30"/685 mm		29.1"/ 740 mm	40.9"/ 1040 mm	47.6"/1210 mm		
	Actuator	ØD = 8.9"/225 mm · A = 25 in ² /160 cm ²											
	Weight ³⁾	lb	35	36	39	54	60	93	104	135	386	915	1047
		kg	16	16.5	17.5	24.5	27	42	47	61	175	415	475
30 to 75 psi/ 2.0 to 5 bar	Height H ^{5) 6)}	23.2"/590 mm · (28"/710) ⁷⁾ mm					26.2"/665 mm · (30.9"/785) ⁷⁾ mm		28.4"/ 720 mm · (33.1"/ 840) ⁷⁾ mm	37.6"/ 955 mm · (42.3"/ 1075) ⁷⁾ mm	43.2"/1095 mm · (47.9"/1215) ⁷⁾ mm		
	Actuator	ØD = 6.7"/170 mm · A = 12 in ² /80 cm ² · (ØD = 8.9"/225 mm · A = 25 in ² /160 cm ²) ⁷⁾											
	Weight ³⁾	lb	35	36	39	54	60	93	104	135	375	904	1036
		kg	16	16.5	17.5	24.5	27	42	47	61	170	410	470
65 to 145 psi ⁴⁾ / 4.5 to 10 bar	Height H ^{5) 6)}	28"/710 mm					30.9"/785 mm		33.1"/ 840 mm)	42.3"/ 1075 mm	47.9"/1215 mm		
	Actuator	ØD = 6.7"/170 mm · A = 12 in ² /80 cm ²											
	Weight ³⁾	lb	35	36	39	54	60	93	104	135	375	904	1036
		kg	16	16.5	17.5	24.5	27	42	47	61	170	410	470

¹⁾ Optionally with actuator 100 in²/640 cm²

²⁾ Optionally with actuator 50 in²/320 cm²

³⁾ The weight applies to the version made of cast iron A126B. Add +10 % for all other materials.

⁴⁾ NPS 6 to 10/DN 150 to 250: 65 to 145 psi/4.5 to 10 bar on request

⁵⁾ Actuators with metal cover H +5.32"/+135 mm

⁶⁾ The height H increases to 7.87"/200 mm at the maximum, depending on the extension piece used.

⁷⁾ Special version A = 25 in²/160 cm² without internal excess pressure limiter; with internal excess pressure limiter: H -2 in/50 mm

Dimensional drawing of Type 42-24 and Type 42-28 balanced by a diaphragm · Dimensions and weights (see Table 5)

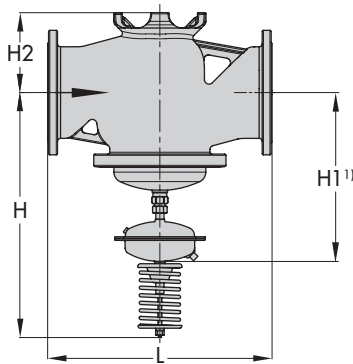

Type 2422 Valve balanced by a diaphragm with Type 2424 Actuator

Dimensional drawing of actuator with two diaphragms

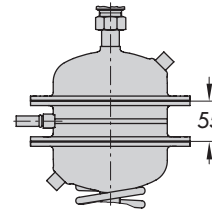

Type 42-24 with two diaphragms: Add approx. 2"/55 mm to the overall height H.

Table 5: Dimensions and weights for Type 42-24 and Type 42-28 · Balanced by a diaphragm

Valve size	NPS	2½	3	4	6	8	10	
	DN	65	80	100	150	200	250	
Length L	Class 125 and 150	in	10.9	11.75	13.9	17.75	21.4	26.5
		mm	276	298	352	451	543	673
	Class 300	in	11.5	12.5	14.5	18.6	22.4	27.9
		mm	292	318	368	473	568	708
Height H2	in	3.9		4.6	6.9	10.2		
	mm	98		118	175	260		
Type 42-28 Differential Pressure Regulator								
Set points		Type 2428 Actuator						
3 · 4 · 6 · 7 psi/ 0.2 · 0.3 · 0.4 · 0.5 bar	Height H1	14"/355 mm		14.8"/375 mm				
	Actuator	ØD = 11.2"/285 mm · A = 50 in ² /320 cm ²						
	Weight, approx. ⁴⁾	lb	84	95	112			
		kg	38	43	51			
Type 42-24 Differential Pressure Regulator								
Set points		Type 2424 Actuator						
Weight, approx. ⁴⁾	lb	93	104	121	210	561	595	
	kg	42	47	55	95	250	270	
0.75 to 3.5 psi/ 0.05 to 0.25 bar	Height H ³⁾	28.3"/720 mm		29.1"/740 mm	33.1"/840 mm	35.8"/910 mm		
	Actuator	ØD = 15.4"/390 mm · A = 100 in ² /640 cm ²						
1.5 to 8.5 psi/ 0.1 to 0.6 bar	Height H ³⁾	22.6"/575 mm		23.4"/595 mm	33.1"/840 mm	35.8"/910 mm		
	Actuator	ØD = 11.2"/285 mm · A = 50 in ² /320 cm ² ¹⁾			ØD = 15.4"/390 mm · A = 100 in ² /640 cm ²			
3 to 14.5 psi/ 0.2 to 1 bar	Height H ³⁾	22.6"/575 mm		23.4"/595 mm	29.9"/760 mm	32.7"/830 mm		
	Actuator	ØD = 8.9"/225 mm · A = 25 in ² /160 cm ² ²⁾			ØD = 11.2"/285 mm · A = 50 in ² /320 cm ² ¹⁾			
7 to 20 psi/ 0.5 to 1.5 bar	Height H ³⁾	22.6"/575 mm		23.4"/595 mm	29.9"/760 mm	32.7"/830 mm		
	Actuator	ØD = 8.9"/225 mm · A = 25 in ² /160 cm ² ²⁾			ØD = 11.2"/285 mm · A = 50 in ² /320 cm ² ¹⁾			
14.5 to 35 psi/ 1 to 2.5 bar	Height H ³⁾	22.6"/575 mm		23.4"/595 mm	29.9"/760 mm	32.7"/830 mm		
	Actuator	ØD = 8.9"/225 mm · A = 25 in ² /160 cm ² ²⁾						
30 to 75 psi/ 2 to 5 bar · 65 to 145 psi ⁴⁾ / 4.5 to 10 bar	Height H ³⁾	22.6"/575 mm		23.4"/595 mm	29.9"/760 mm	32.7"/830 mm		
	Actuator	ØD = 8.9"/225 mm · A = 25 in ² /160 cm ² ²⁾						

¹⁾ Optionally with actuator 100 in²/640 cm²

²⁾ Optionally with actuator 50 in²/320 cm²

³⁾ Actuators with metal cover H +5.32"/+135 mm

⁴⁾ The weight applies to the version made of cast iron A126B. Add +10 % for all other materials.